

AI 4K UHD Video Conference Camera

User Manual (V1.0)

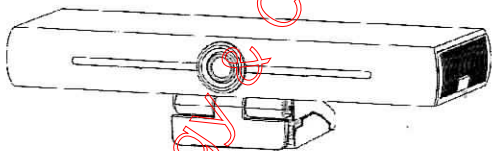

目录

ATTENTIONS.....	1
1. FAST INSTALLATION.....	2
1.1 CAMERA INTERFACE.....	2
1.2 CAMERA OPERATION.....	2
2. PRODUCT OVERVIEW.....	2
2.1 PRODUCT INTRODUCTION.....	2
2.1.1 Product Model.....	2
2.1.2 Dimensions.....	3
2.1.3 Accessories.....	3
2.2 MAIN FEATURES.....	3
2.3 TECHNICAL SPECIFICATIONS.....	4
2.4 INTERFACE INSTRUCTION.....	5
2.4.1 External Interface.....	5
3. APPLICATION INSTRUCTION.....	6
3.1 REMOTE CONTROLLER.....	6
3.1.1 Keys Instruction.....	6
3.1.2 Applications.....	7
3.2 MENU SETTING.....	9
3.2.1 Main Menu.....	9
4. MAINTENANCE AND TROUBLESHOOTING.....	13
4.1 MAINTENANCE.....	13
4.2 TROUBLESHOOTING.....	14
COPYRIGHT STATEMENT.....	14

VLV Technology & Communications

Attentions

This manual introduces functions, installation and operations for the camera in details. Please read this manual thoroughly before installation and use.

1. How to Use

To prevent damage to this product or any product connected to it, this product can only be used within the specified range.

- 1). Do not expose the product to rain or moisture.
- 2). To prevent the risk of electric shock, do not open the case. Installation and maintenance should only be carried out by qualified technicians.
- 3). Do not use the product beyond the specified temperature, humidity or power supply specifications.
- 4). Wipe it with a soft, dry cloth when cleaning the camera lens. Wipe it gently with a mild detergent if needed. Do not use strong or corrosive detergents to avoid scratching the lens and affecting the image;

2. Electrical Safety

Installation and use of this product must strictly comply with local electrical safety standards.

3. Handle with Care

Avoid damage to product caused by heavy pressure, strong vibration or immersion during transportation, storage and installation.

4. Install with Caution

- 1). Do not rotate the camera head violently, otherwise it may cause mechanical failure;
- 2). This product should be placed on a stable desktop or other horizontal surface. Do not install the product obliquely, otherwise it may display inclined image;
- 3). If the camera is installed on TV or computer, the base can be fixed by four double-sided adhesive trays.
- 4). Housing of this product is made of organic materials. Do not expose it to any liquid, gas or solids which may corrode the shell.
- 5). Ensure there are no obstacles within rotation range of the holder.
- 6). Do not power on before completely installation.

5. Do not Disassemble the Product Without Permission

This product contains no parts which can be maintained by users themselves. Any damage caused by dismantling the product by user without permission is not covered by warranty.

6. Magnetic Interference

Electromagnetic fields at specific frequencies may affect the image. This product is Class A. It may cause radio interference in household application. Appropriate measure is required.

1. Fast Installation

1.1 Camera Interface

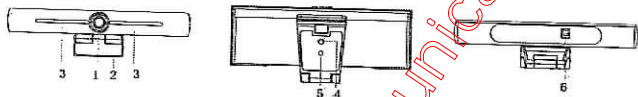

Figure 1.1 camera interface

1. camera lens
2. bracket

3. built-in MIC
4. lipod fixing hole

5. positioning hole
6. USB 3.0 output interface

1.2 Camera Operation

- 1) Product Installation: Fix the device on LCD screen, top of computer; directly put it on desk or on tripod mounting.
- 2) Connect camera via USB cable to computer, video conference terminal or other USB input device, log in the video conference software and select a video device to have image output.

2. Product Overview

2.1 Product Introduction

2.1.1 Product Model

MG200-XX

AM – 83° VCM Motor Lens
BM – 87° Fixed Lens
HM – 120° Fixed Lens

Figure 2.1 Product Model

2.1.2 Dimensions

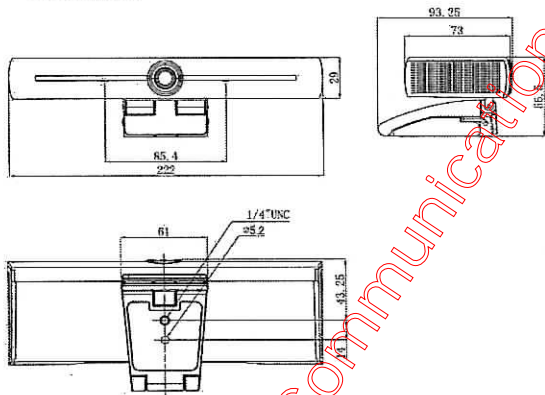

Figure 2.2 Camera Dimensions

2.1.3 Accessories

Check and confirm all accessories are provided as listed in sheet 2.1.

Accessories	User manual 1
	Wireless remote controller 1 piece
	USB3.0 cable 1 piece
	Warranty card 1 piece
	Cushion

Sheet 2.1 Product accessories

2.2 Main Features

This product is a new 4K UHD ePTZ video conference camera. It is built with AI functions, which can automatically frame all people in the meeting and make them at the middle of the scene. It also has perfect functions and superior performance, which adopts advanced ISP processing algorithms so as to provide vivid images with evenly clear brightness, strong color layering, high resolution, and fantastic color rendition. Easy and convenient to install and maintain, stable and reliable.

- 4K UHD: It employs 1/2.5 inch, 8 million pixels high quality CMOS sensor; supports 4K

UHD; provides 4K@ 30fps MJPG video resolution at most; and provides clear UHD video and vivid expressions and movements. At the same time, it is compatible with 1080p and 720p resolution.

- **EPTZ:** EPTZ and 4X digital Zoom
- **Built-in pickup:** Includes 2 built-in pickups, all-round pickup. Antique noise suppression algorithm ensures your voice be perfect. The effective pickup distance is up to 5 meters.
- **Dual stream output:** The USB3.0 port support main stream and sub-stream output at the same time.
- **Auto framing:** With excellent facial detection algorithm, automatically adjust the zoom according to the number of people in the meeting. It can frame all the meeting people and make them shown in the middle of the scene.
- **Wide view angle without distortion:** 83°/ 87°/ 120° super wide view angle lens for options
- **Low Noise and High SNR:** Low Noise CMOS effectively ensures high SNR of video. Image is still clear even under low light condition.
- **Multiple Installations:** Standard equipped with mold clamp. Easy to install on any devices, such as LCD screen, PC, table and tripod.
- **Easy to Use:** No need to download driver; USB Plug and play.
- **Wide Applications:** Personal video conferencing, enterprise video conferencing, unified collaboration and etc.

2.3 Technical Specifications

Model Number	AM	BM	HM
Camera Parameter			
Image Sensor	1/2.5 Inch High Quality 4K CMOS Sensor		
Effective Pixels	8.28MP 16:9		
Video output port	1* USB3.0, Type B, support audio output over USB3.0		
Audio input	2 built-in MIC pickups		
View Angle	93.5°(D)/83°(H)/53.1°(V)	95°(D)/87°(H)/56°(V)	126°(D)/120°(H)/85°(V)
Video Format	Main stream: 3840×2160@30fps, 1920×1080P@30fps/25fps, 1280×720P@30fps/25fps, etc. Sub-stream: 1280×720P@30fps/25fps, 640×480P@30fps/25fps, 320×172P@30fps/25fps, etc.		
Min Illumination	0.1Lux (F1.8, AGC ON)		
Lens	f=1.5mm	f=3.24mm	f=2.72mm
Aperture	F2.0±5%	F2.1	F2.5
Digital zoom	4X		
DNR	2D & 3D DNR		
Ultra-low illumination	On/off		
White Balance	Auto / Manual/ One Push/ 3000K/ 3500K/ 4000K/ 4500K/ 5000K/ 5500K/ 6000K/ 6500K/ 7000K		
Focus	Auto / Manual/ One push Focus (available on AM series)		
Exposure	Auto / Manual		
Auto framing	On/off/sensitivity		
Backlight compensation	On/off		
Dual stream	On/off		
SNR	>55dB		

USB Feature	
Operation Systems	Windows 7(1080p at the most), Windows 8.1, Windows 10 ; macOS™ 10.10 or higher, Linux (Require to support UVC.)
Video Compression format	YUY2, MJPG, H.264, H.265
Audio over USB3.0	Support
USB communication protocol	UVC, UAC
PTZ control	Support EPTZ
Hardware requirement	2.4 GHz Intel® Core 2 Duo processor or higher, 2GB RAM or more, USB 2.0 /USB3.0 port (USB 3.0 is needed for 4K)
Other Parameters	
Input Voltage	5V
Input Current	1A(Max.)
Power consumption	5W(Max.)
Store Temperature	-10℃ ~+60℃
Store Humidity	20% ~90%
Working Temperature	-10℃ ~+50℃
Working Humidity	20% ~80%
Dimension (W*H*D)	222mm×93.25mm×56.5mm
Weight	Around 0.53kg
Application	Indoor
Accessory	User Manual; Warranty card, remote controller, USB3.0 cable

2.4 Interface Instruction

2.4.1 External Interface

The interface illustration is as Figure 2.4 below.

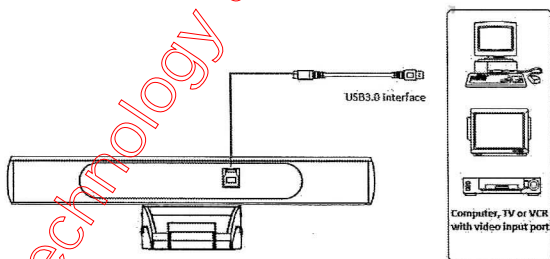
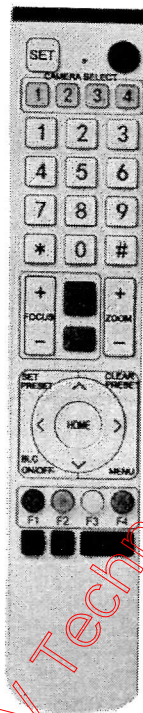

Figure.2.4 Interface Diagram

3. Application Instruction

3.1 Remote Controller



3.1.1 Keys Instruction

1. Standby Key

After 3s long press, the camera will be in standby mode. Long press 3s again, the camera will self-test again and back to HOME position. Note: If preset 0 is set, there is no operation within 12s, camera head will automatically point to the specified preset 0 position.

2. Camera Address Selection

Select the camera address

3. Number Key

Set or call 0-9 presets

4. *, # Key

Key combination use

Long Press 5s "SET" + "*" at the same time, the WR controller is light on, releases hands. Power on the camera again, it will successfully paired with WR controller.

Long Press 5s "SET" + "#" at the same time, the WR controller is light on, releases hands. Power on the camera again, it will cancel to paired with WR controller.

5. Focus Control Key

Auto Focus: Enter into auto focus mode.

Manual Focus: The camera focus mode is manual

Switch the camera focus mode to manual focus by pressing [focus +] or [focus -] to adjust.

6. Zoom Control Key

Zoom +: Lens near

Zoom -: Lens far

7. Set or Clear Preset key:

Set Preset: Set preset key + 0-9 number key

Clear Preset key: Clear preset key + 0-9 number key

8. Electronic Pan/Tilt Control Key

Press Key : Up

Press Key : Down

Press Key : Left

Press Key : Right

"HOME" Key: Return to the middle position or enter into the sub-menu

9. BLC Control Key

Back Light ON / OFF: Turn on or off the back light

10. Menu Setting

Open or close the OSD menu

Enter / exit the OSD menu or return to the previous menu

11. Address Setting

- 【*】+【#】+【F1】:Camera Address No.1
- 【*】+【#】+【F2】:Camera Address No. 2
- 【*】+【#】+【F3】:Camera Address No. 3
- 【*】+【#】+【F4】:Camera Address No. 4

12. Key Combination Functions

- 1) 【#】+【#】+【#】:Clear all presets
- 2) 【*】+【#】+【6】:Restore factory defaults
- 3) 【*】+【#】+【9】:Flip switch
- 4) 【*】+【#】+【4】:Menu set to English
- 5) 【*】+【#】+【3】:Menu set to Chinese
- 6) 【*】+【#】+【0-9】: Switch video format
- 7) 【*】+【#】+Manual: Restore the default user name, password, and IP address

3.1.2 Applications

Power on the camera, press the "SET" and "*" keys together for 5 seconds, the indicator light will be on. Then release the button and power on the camera again when the light is flashing. The matching process will be done when the indicator light stops flashing. Then users can control the pan/tilt/zoom, set and call preset positions via the wireless remote controller.

Key Instruction:

- 1. In this instruction, "press the key" means a click rather than a long-press, and a special note will be given if a long-press for more than one second is required.
- 2. When a key-combination is required, do it in sequence. For example, 【*】+【#】+【F1】 "means press" 【*】 "first and then press" 【#】 "and last press" 【F1】 ".

1) Camera Selection



Select the camera address to control.

2) Pan/Tilt Control

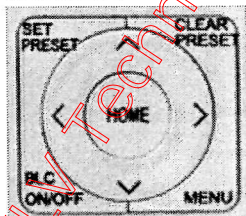

- Up: press ▲
- Down: press ▼
- Left: press ◀
- Right: press ▶
- Back to middle position: press" 【HOME】 "

Press and hold the up/down/left/right key, the pan/tilt will keep running, from slow to fast, until it runs to the endpoint; the pan/tilt running stops as soon as the key is released.

3) Presets

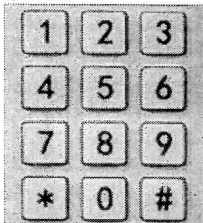

1. Preset setting: to set a preset position, the users should press the "【SET PRESET】" key first and then press the number key 0-9 to set a relative preset,

Note: 10 preset positions in total are available by remote controller.

2. Preset calling: Press a number key 0-9 directly to call a relative preset.

Note: Action in vain if a relative preset position is not existed.

3. Preset clearing : to clear a preset position, the user can press the "【CLEAR PRESET】" key first and then press the number key 0-9 to clear the relative preset;

Note : press the"【#】" key three times continually to cancel all the presets.

4) Zoom Control

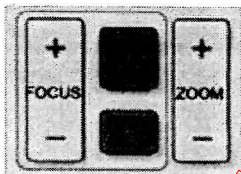

ZOOM IN: press "ZOOM ▲" key

ZOOM OUT: press "ZOOM ▼" key

Press and hold the key, the camera will keep zooming in or zooming out and stops as soon as the key is released.

5) Focus Control

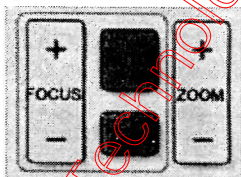

Focus (near): Press "【focus+】" key (Valid only in manual focus mode)

Focus (far): Press "【focus-】" key (Valid only in manual focus mode)

Auto Focus: yes

Manual Focus: yes

Press and hold the key, the action of focus will keep continue and stops as soon as the key is released.

6) Address Setting



- 【*】+【#】+【F1】:Camera Address No.1
- 【*】+【#】+【F2】:Camera Address No. 2
- 【*】+【#】+【F3】:Camera Address No. 3
- 【*】+【#】+【F4】:Camera Address No. 4

3.2 MENU SETTING

3.2.1 Main Menu

When use MJPG/H.264 / H.265 compression , press **【MENU】** key to display the menu, using scroll arrow to point at or highlight the selected items.

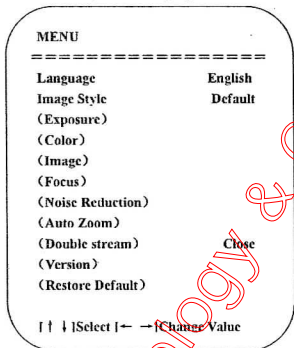

1. Language Setting: press **【←→】** key to select Language

2. Image Style Setting: press **【←→】** key to select style

3. Exposure Setting

Move the pointer to EXPOSURE in the Main Menu, click the **【HOME】** and enter the (EXPOSURE SET) as follows:

EXPOSURE

Mode	Auto
EV	OFF
BLC	OFF
Flicker	50Hz
G.Limit	3
DRC	2

[↑ ↓]Select [← →]Change Value

Mode : Auto, Manual, Shutter priority, Iris priority and Brightness priority.

EV : On/Off (only available in auto mode)

Compensation Level: -7~7 (only available in auto mode when EV is ON)

BLC: ON/OFF for options (only available in auto mode). **Dynamic range:** adjustable items: 1 ~ 8, close

Anti-Flicker: OFF/50Hz/60Hz for options (only available in Auto/Iris priority/Brightness priority modes)

Gain Limit: 0~15(only available in Auto/ Iris priority /Brightness priority mode)

WDR: Off,1~8

Shutter Priority:

1/25,1/30,1/50,1/60,1/90,1/100,1/120,1/180,1/250,1/350,1/500,1/1000,1/2000,1/3000,1/4000, 1/6000, 1/10000 (only available in Manual and Shutter priority mode)

Brightness: 0~23 (only available in Brightness priority mode)

4. Color Setting

Move the pointer to COLOR in the Main Menu, click the **【HOME】** and enter the (COLOR SET) as follows:

COLOR

WB Mode	Auto
RG Tuning	0
BC Tuning	0
Saturation	100%
Hue	7
AWB Sensitivity	High

[↑ ↓]Select [← →]Change Value

WB Mode: Auto, Manual, One Push, 3000K, 3500K, 4000K, 4500K, 5000K, 5500K, 6000K,

6500K, 7000K

RG Tuning: -10~10 (only available in Manual mode)

BG Tuning: -10~10 (only available in Manual mode)

Red Gain: 0~255 (only available in Manual mode)

Blue Gain: 0~255 (only available in Manual mode)

Saturation: 60%, 70%, 80%, 90%, 100%, 110%, 120%, 130%, 140%, 150%, 160%, 170%, 180%, 190%, 200%

Hue: 0~14

AWB Sensitivity: high/middle/low (only available in Manual mode)

5. Image Setting

Move the pointer to IMAGE in the Menu, click the **[HOME]** and enter the (IMAGE) as follows,

IMAGE	
Brightness	7
Contrast	7
Sharpness	4
Flip-H	OFF
Flip-V	OFF
B&W-Mode	Color
Gamma	Default
DCI	Close
Low-Light Mode	Close
[↑ ↓]Select [← →]Change Value	

Brightness: 0~14

Contrast: 0~14

Sharpness: 0~15

Flip-H: On/Off

Flip-V: On/Off

B&W Mode: color, black/white

Gamma: default, 0.45, 0.50, 0.55, 0.63

DCI: Dynamic Contrast: Off, 1~8

6. Focus Setting

Move the pointer to FOCUS in the Menu, click the **[HOME]** and enter the (FOCUS) as follows:

FOCUS	
Focus Mode	Auto
AF-Zone	Center
AF-Sensitivity	Low
[↑ ↓]Select [← →]Change Value	

Focus Mode: Auto, manual, one-push
 AF-Zone: Up, middle, down, overall
 AF-Sensitivity: High, middle, low

7. Noise Reduction Setting

Move the pointer to NOISE REDUCTION in the Menu, click the [HOME] and enter the (NOISE REDUCTION) as follows,

NOISE REDUCTION	
NR-2D	2
NR-3D	5
Dynamic Hot Pixel	OFF
[↑ ↓]Select [← →]Change Value	

2D Noise Reduction: Auto, close, 1-7
 3D Noise Reduction: Close, 1-8
 Dynamic Hot Pixel: Close, 1-5

8. Auto Framing Setting

Move the pointer to Auto Framing in the Menu, click [← →] keys to set ON/OFF.

Auto Framing	
Auto Framing	Close
[↑ ↓]Select [← →]Change Value	

9. Dual Stream Setting

Move the pointer to Dual Stream in the Menu, click [← →] keys to set ON/OFF.

10. Version

Move the pointer to VERSION

VERSION		
=====		
Cam Version	1.0.0	2019-7-31
Focus Version	1.0.6	2018-8-21
[↑ ↓]Select [← →]Change Value		

11. Restore Default

Move the pointer to RESTORE DEFAULT in the Main Menu, click **[HOME]** and enter RESTORE DEFAULT as below:

RESTORE DEFAULT		
=====		
Restore Default?		NO
[↑ ↓]Select [← →]Change Value		

Restore default: Yes/No for options. (the video format and color style won't be restored)

Note: If the address of former remoter is not 1 but another one from 2,3,4, the corresponding camera address will restore to 1 when all parameters or system parameters are restored. User should change the remoter address to be 1 (press No.1 according to the camera so to get normal operation)

4.Maintenance and Troubleshooting

4.1 Maintenance

- 1) Please disconnect the camera if it is not used for a long time.
- 2) Use soft cloth or tissue to clean the camera cover.
- 3) Wipe it with a soft, dry cloth when cleaning the camera lens. Wipe it gently with a mild detergent if needed. Do not use strong or corrosive detergents to avoid scratching the lens and affecting the image;

4.2 Troubleshooting

1) No video output

- a. Check whether USB cable connected well and power indicator light is ON.
- b. Whether the machine could do self-check after restarted.
- c. Restart PC
- d. Check whether the camera is well recognized by PC

2) No image sometimes

- a. Check the USB cable quality and whether connected well.

3) Image dithering when zoom-in or zoom-out

- a. Check whether the camera installation position is solid
- b. Whether there is shaking machine or objects around the camera

4) Remote controller cannot work

- a. Re-match the camera and the wireless remote controller
- b. Set the camera address to 1 (The camera address would be back to 1 after restore default setting)
- c. Check whether the battery is installed on the remote controller or low .
- d. Check the camera working mode is the normal operating mode (see Table 2.2 and Table 2.3)
- e. Exit the menu, the menu only displayed under MJPG/H.264/H.265 compression format.

Copyright Statement

All the contents in this manual and its copyright are owned by the company. No one is allowed to imitate, copy, or translate this manual without the company's permission. This manual contains no guarantee, standpoint expression or other implies in any form. Product specification and information in this manual is for reference only and subject to change without notice.

All rights reserved. No reproducing is allowed without acknowledgement.

AI 4K UHD Video Conference Camera

User Manual (V1.0)

